

Laboratori Nazionali di Frascati

LNF-62/79 (1962)

G. Sacerdoti, L. Tau: A DOUBLE FOCUSING, ALTERNATE-GRADIENT,
MAGNETIC SPECTROMETER FOR MOMENTA UP TO 800 MeV/c.

Estratto dal: Nuclear Instruments and Methods, 16, 139 (1962)

A DOUBLE-FOCUSSING, ALTERNATE-GRADIENT, MAGNETIC SPECTROMETER FOR MOMENTA UP TO 800 MeV/c

GIANCARLO SACERDOTI

Laboratori Nazionali del Sincrotrone, Frascati, Roma

and

LUCIANO TAU

Istituto di Fisica dell'Università, Roma — Istituto Nazionale di Fisica Nucleare, Sezione di Roma

Received 27 March 1962

A 40° deflecting magnetic spectrometer has been built for use in experiments with the 1.1 GeV photon beam of the Frascati electro-synchrotron. It consists of two strong-focussing alternate-gradient pole sectors, the first producing a field index $n = +25$ and the second $n = -20$, assembled on a single yoke with no straight section in the middle. The curvature radius being 250 cm, a dispersion results of 0.03/cm, and focussing in both horizontal and vertical planes is obtained at 261 cm from

the source position. The deflection is horizontal, and angular distributions can be measured from 0° to 180° without allowing the primary beam to strike the magnet. Calibration measurements with a Po^{210} α source which extended 5 cm horizontally and 2.5 cm vertically have given 0.0056 steradians as the available solid angle, and have confirmed the position of the conjugate points.

1. Introduction

Many low counting-rate experiments on short-lived particles, such as pions or K mesons, can be performed with the 1.1 GeV photon beam of the Frascati electro-synchrotron if a spectrometer magnet is available which combines a large solid angle with a short target-detector distance. With this in mind, a spectrometer was built about one year ago, which is an 800 MeV/c version of the 100 MeV/c analyzer designed by Martin and Kraus¹). This last consists of two 15° deflecting alternate-gradient magnets, based on the strong-focusing properties discovered by Courant, Livingston and Snyder²).

Some modifications have been made to the Martin and Kraus design, chief among them being (i) different shaped poles and coils, which, in producing the constant gradient field without the need for a neutral pole, permit measurements of

angular distributions in the full solid angle from 0° to 180° without allowing the primary beam to strike the magnet, and (ii) the elimination of the straight section between the two sectors, thus increasing its acceptance and decreasing the target-detector distance.

2. Choice of Optical Parameters

Wishing to operate the spectrometer at momenta comparable to the maximum momentum of our photon beam, we selected $R = 250$ cm as the curvature radius. With this, 750 MeV/c particles are focused when the field strength is 10 kilogauss at the central trajectory, thus leaving some degree of freedom for the choice of field gradients without being limited by saturation effects. Next we selected the horizontal plane as the plane of bending, 20° as the deflection angle in each of the two lenses, $n_1 = +25$ and $n_2 = -20$ as their field indices, and 9 cm as the height of the gap at the central ray.

A first order matrix method calculation³) gives the double-focusing positions of object and image, and also the horizontal and vertical magnifications, and the dispersion. They are:

¹) H. J. Martin and A. A. Kraus, *Rev. Sci. Instr.* **28** (1957) 175. A spectrometer based on the same principles has been built by R. Wilson at Cornell (not published).

²) Courant, Livingston and Snyder, *Phys. Rev.* **88** (1952) 1190.

³) See for instance: S. Penner, *Rev. Sci. Instr.* **32** (1961) 150.

- S_1 = distance between object and entrance face of the magnet = 31 cm;
 S_2 = distance between exit face and image = 56 cm;
 S = total object to image distance = 261 cm;
 M_h = linear magnification in the horizontal plane = 0.2;
 M_v = linear magnification in the vertical plane = 6;
 D = the dispersion at the image position = 0.03/cm.

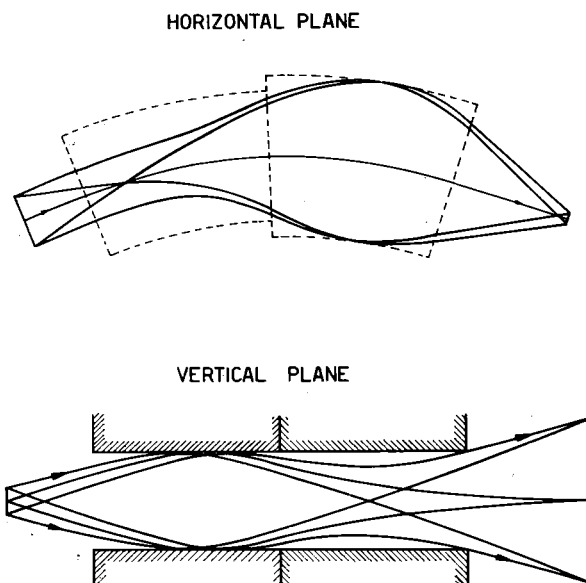

Fig. 1. A few of the calculated trajectories. The drawing refers to a source which extends 5 cm horizontally and 2.5 cm vertically. In the drawing, the scale units for the radial and vertical directions have been chosen 5 times larger than the scale unit in the direction of particle motion.

The same matrix method gives the trajectories shown in fig. 1. These confirm that the vertical object extension seen by the detector is 2.5 cm, as required by the size of the photon beam at our target position.

The advantage of having a positive n in the first sector has already been discussed by Martin and Kraus: demagnification occurs in this case in the plane of bending, which decreases the effect of the finite size of the target on the spectrometer resolving power. Also, the angular interval so accepted is narrow in the horizontal plane and wide in the vertical, a feature which, in minimizing the effect of the cross-section variation with the observation angle, turns out to be an advantage whenever this angle is different from 0° .

A relation exists between the field index and the

maximum radial extension obtainable for the constant gradient region; it is $\Delta r_{\max} = 2R/n$. Both this, and saturation effects at points where the field is strong, have been kept in mind in choosing n_1 and n_2 . Thus, a shorter object-to-image distance could have been obtained by using stronger gradients, but this would have resulted in a narrowing of the useful gap in the radial direction, and hence in a smaller accepted solid angle.

However, the choice of different n 's in the two sectors still remains to be explained. To this end, consider a spectrometer with equally strong gradients in both lenses, let us say $n_1 = +20$ and $n_2 = -20$. We insist that its design can be improved by merely increasing n_1 , and leaving the other parameters unchanged. Indeed, in doing so, the object position comes nearer to the magnet, thus solid angle is gained, and nothing is lost by the resultant narrowing of the gap in the first sector, this being consistent with the shape of the trajectories in the horizontal plane (see fig. 1).

3. Model Testing and Magnet Design

Tests were performed on the poles of a model in order to produce the selected gradients with no neutral iron slab at the wide gap asymptote. The

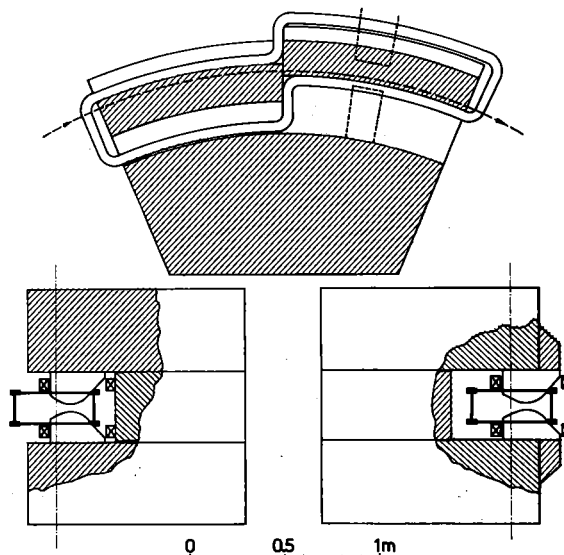

Fig. 2. A scale drawing of the final magnet design. The unusual shape of the energizing coils, and the stainless-steel vacuum tank used for α particle calibration measurements are also shown. Dashed lines in the middle of the second sector indicate the position of a baffle, which extends 20 cm azimuthally and has a radial opening of 15 cm, centered on the central trajectory.

twofold aim was to avoid slab saturation effects and to enable the spectrometer to be used at forward and backward angles without having it struck by the photon beam. No significant departure from the required linear fields was found over radial gap extensions which are 60% of the

keep the coil temperature down to 60°C. A 600-kW generator available here supplies the required 250-kW excitation power.

Poles and coils are assembled on a single yoke, built symmetrically with respect to its median plane. Therefore, by simply turning the spectrometer upside down, all angles of observation can be reached on both sides of the primary beam. In ad-

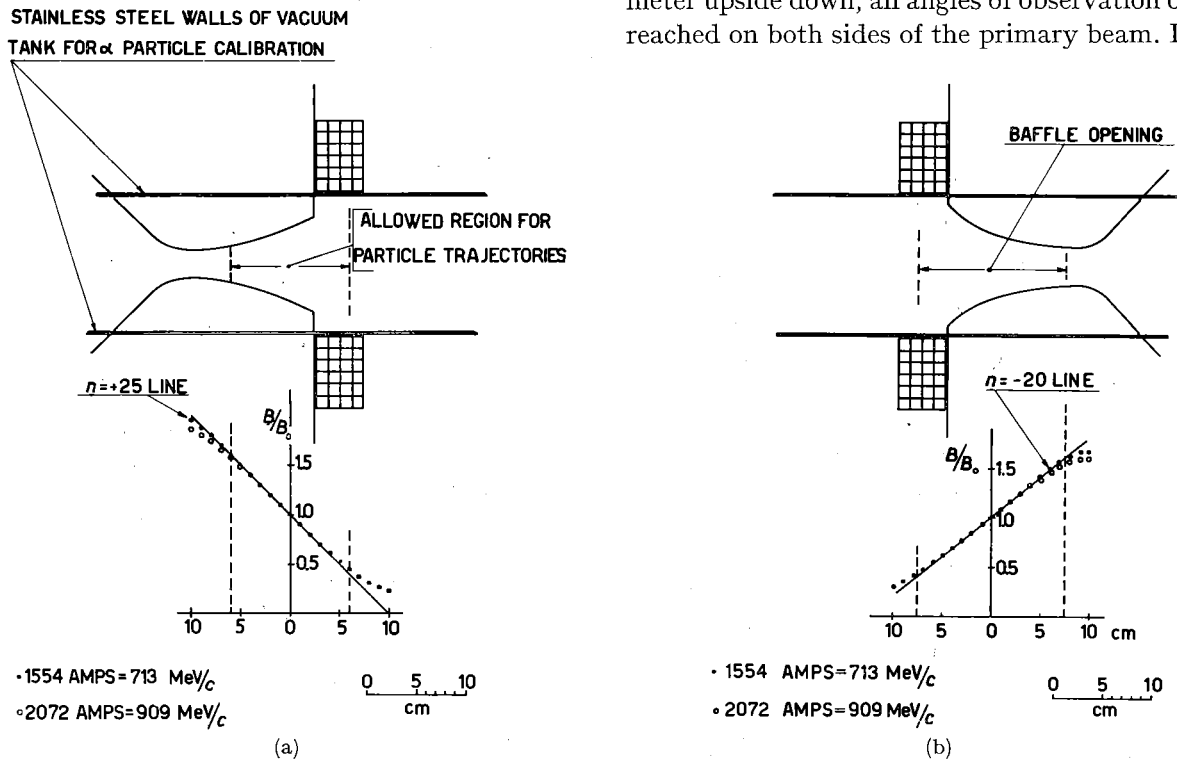

Fig. 3. Section of poles and coils in the two sectors. The figure also shows the results of the field gradient measurements and the 3 mm thick walls of the vacuum tank.

maximum obtainable, providing that (i) the hyperbolic trends of the pole faces are truncated as shown in fig. 3, and (ii) the energizing coils are small in cross-section and located very close to the poles and to the symmetry plane of the magnet.

Both these results are strongly reflected in our magnet design, the essential parts of which are shown in fig. 2. The two coils are of unusual shape, so that they can closely follow the truncated pole contour, and each consists of only 24 turns of 12×12 mm² section copper tubing having a central hole of 7 mm diameter for the cooling water. A rather high current density of 20 A/mm² results when the spectrometer is operated at maximum field, and a water pressure of 20 atm is needed to

dition, the design includes a stainless steel vacuum tank within which the tapered parts of the poles are located. This was used for alpha particle calibration measurements, and is removed when high energy experiments are performed. The total weight of the magnet is 15 tons.

4. Field Measurements

The excitation curve for the magnet is shown in fig. 4. The measurements were made with an electronic fluxmeter of the Dicke type⁴) in conjunction with a small coil, about 1 cm in diameter and 1 cm in height, placed in the magnet symmetry plane at the central trajectory. Gauss values for the field

⁴) R. H. Dicke, Rev. Sci. Instr. 19 (1948) 533.

were obtained by intercalibration of the coil with the probe of a nuclear resonance fluxmeter located in a small magnet with uniform field.

Measurements of the field gradient were made in the symmetry plane, with currents of 518, 1036, 1554 and 2072 A. The results obtained at 1554 and

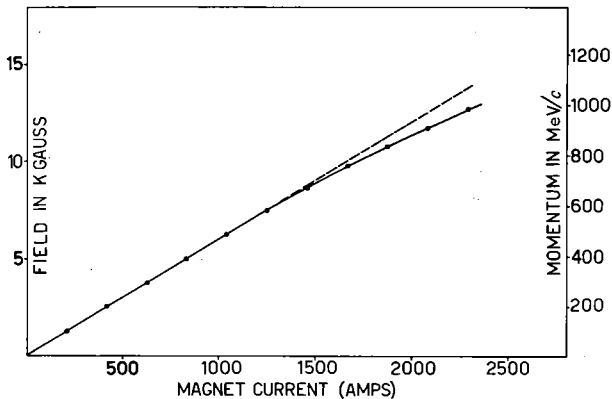

Fig. 4. Excitation curve for the magnet: measurements were taken at the central trajectory. Momentum values given by the scale to the right are obtained from the α -particle calibration.

2072 A are shown in fig. 3; results for the lower currents are not shown as they are the same as those obtained at 1554 A. From fig. 3 we see that the spectrometer operation and the extrapolation of the alpha particle measurements (see next paragraph) can be trusted at least up to momenta of 700 MeV/c. At 900 MeV/c saturation effects reduce the radial region of constant gradient, and the extrapolation of the alpha particle calibration becomes doubtful. However, we expect that even at 900 MeV/c the spectrometer still operates effectively as we believe that it retains most of its focusing properties. Measurements of the field gradient were also made at a distance of 1.5 cm above the symmetry plane; the results are similar to those shown in fig. 3.

A transition region exists, of course, around the plane which separates the two sectors of the spectrometer. Here the gradient in each sector gradually decreases to match that of the other, and as the field might be sensitive to saturation at the sharp edges of the poles, the corners of these were rounded to obtain smooth pole faces.

5. Alpha Particle Calibration

In order to use the spectrometer to the fullest advantage, one must know, in addition to the focused momentum at each selected current, the accepted solid angle and the resolution curve. This, more than the knowledge of optical properties such as the actual shape of the trajectories, is required when the spectrometer is employed to measure absolute cross-sections in high energy experiments. Alpha particle measurements were therefore preferred to the floating wire technique for the magnet calibration.

A Po^{210} α -source, kindly prepared for us by Dr. D. Cordischi of the Chemistry Institute of Rome University, was located in the previously mentioned vacuum tank and centered on the central trajectory at 31 cm from the entrance face of the magnet. As a detector, we used a plastic scintillation counter, located at 56 cm from the exit face and viewed by a DuMont 6364 photomultiplier through a plexiglass light pipe 8 cm in length.

A baffle was placed in the middle of the second lens, as shown by the dashed lines in fig. 2. It extended 20 cm azimuthally, and accepted, through its radial opening of 15 cm, a horizontal angle of about 2.5 degrees.

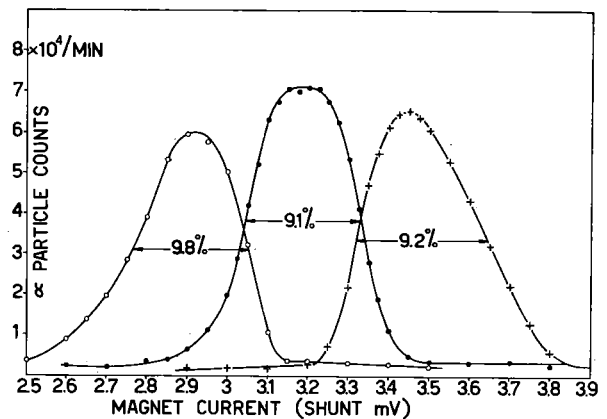

Fig. 5. Resolution curves for three adjacent detectors, each having a horizontal extension of 3 cm.

The dimensions of source and detector were determined by the requirements of the first high energy experiment in which we intended to employ the spectrometer. Thus, the source extended 5 cm radially and 2.5 cm vertically, so as to reproduce our target, and, as the vertical magnification is 6,

the counter height was made 15 cm. In addition, the counter was made 3 cm wide, so that the 3%/cm dispersion caused it to accept a momentum band of 9%, and measurements were made in three ad-

measured and found to emit 7.7×10^7 α 's per minute. From this was obtained the solid angle accepted by the spectrometer in each channel, i.e. 0.0046 ster. for the high momentum channel,

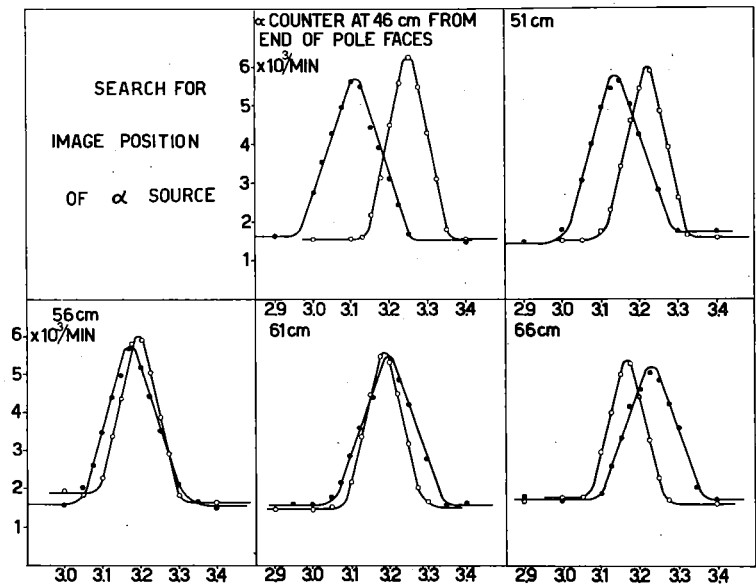

Fig. 6. Search for image position of α -source. Counting rates of α -particles are plotted versus shunt millivolts of magnet current. See text for experimental conditions. At image position black point curve is superposed upon open point curve.

acent positions so as to obtain the resolution curves of three detectors selecting three adjacent momentum channels.

The response of the spectrometer for the three channels is shown in fig. 5. The source was also

0.0056 ster. for the central channel and 0.0051 ster. for the low momentum channel.

Some measurements were also made to verify that the image of the source was in the expected position. The image position can be obtained if one finds the intersection of two α -particle pencils emitted in the horizontal plane at two different angles. To this end, the baffle was altered to define a radial opening of 1 cm, which was centered first at a radius of 254 cm and then at a radius of 246 cm. The measurements were taken with the counter made 1 cm wide, and located successively at 46, 51, 56, 61 and 66 cm from the exit face. Fig. 6 shows the counting rate versus shunt millivolts under these conditions: the black points refer to measurements taken with the baffle opening at the 246 cm radius, and the open points to measurements with the opening at the 254 cm radius. At the image position, of course, the black point curve and the open point curve completely overlap. This occurs at 58 cm from the exit face, as can be seen

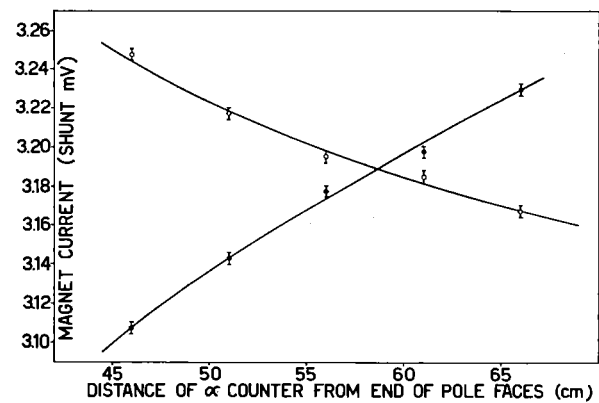

Fig. 7. Search for image position of α -source. Shunt millivolts which give peak counting-rates in fig. 6 are plotted versus distance of α -counter from the exit face of the magnet. The intersection of the two curves drawn through the experimental points gives the image position at 58 cm from the exit face.

from the intersection point of the two curves of fig. 7, where the millivolt values of fig. 6 which give the maximum counting rate have been plotted versus position of the α counter. This very good agreement, within 1%, of the observed with the calculated values for the object-to-image distance was of course expected, as the coil position, very close to the median plane of the spectrometer, makes the effective magnetic edges almost coincident to the geometrical edges of the pole faces.

In conclusion, the spectrometer has been successfully operated for about 1000 hours in an experiment in which coincidences from muon pairs

photoproduced in a carbon target have been detected⁵).

Acknowledgements

To the authors of the muon pair experiment, especially to Prof. A. Odian and G. Stoppini and to Drs. M. De Pretis and G. Marini, go our thanks for their very useful suggestions, and for their help, together with that of Dr. R. Visentin, throughout the various stages of this work. Thanks are also due to Prof. F. Salvetti and Dr. D. Cordischi, who kindly prepared the polonium α -source.

⁵) A. Alberigi, M. De Pretis, G. Marini, A. Odian, G. Stoppini and L. Tau (to be published).